

Revision	Date
00	03/12/2023

SYSTEM SPEC:	
Capacity	6000lbs
Construction	STEEL
Lowered Height	24.25"
Raised Height	144"
Platform	48" Wide X 96" Long
Fork	48" Wide X 96" Long
Drive System	Single Heavy Duty Drive With Advance DC motor
Brakes	Electric
Voltage	24 VAC U.L. 583 Type E
Controls	Solid State Electronic Controller With Infinite Speed Control And Battery Conservation
Steering	Manual Tiller Style
Tire	9" x 5" Polyurethane Drive
Load Wheel	3" Dia.
Battery Comp.	28" Long x 7.75" Wide x 24" Height Compartment
Battery Connector	SB-175 Red
Finish	Tig Welded and Electropolished

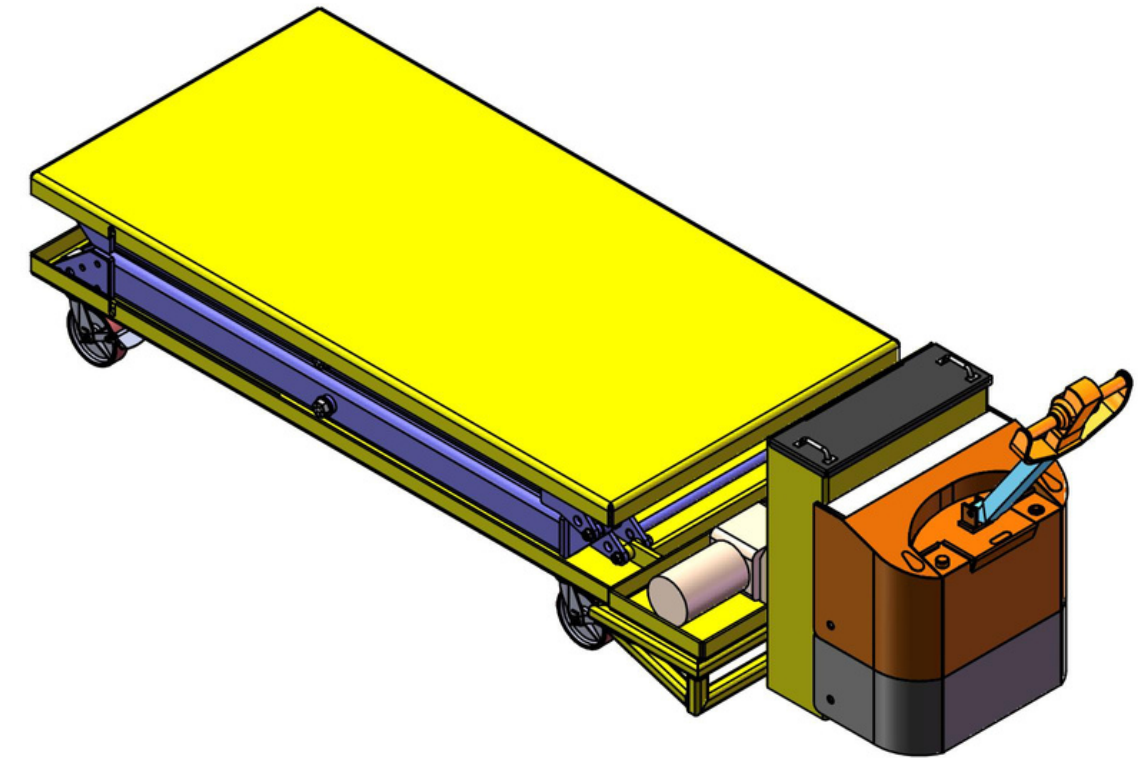
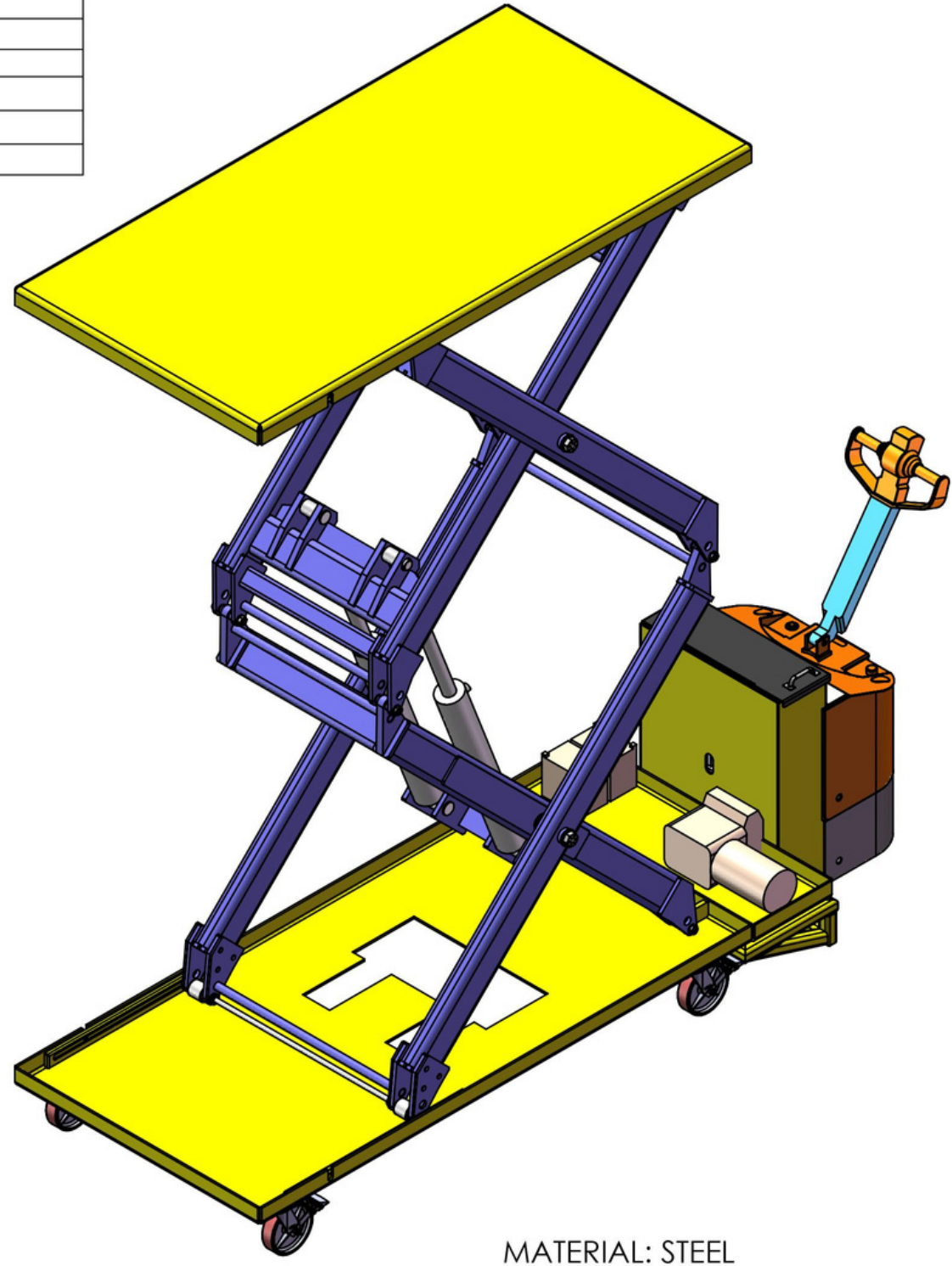
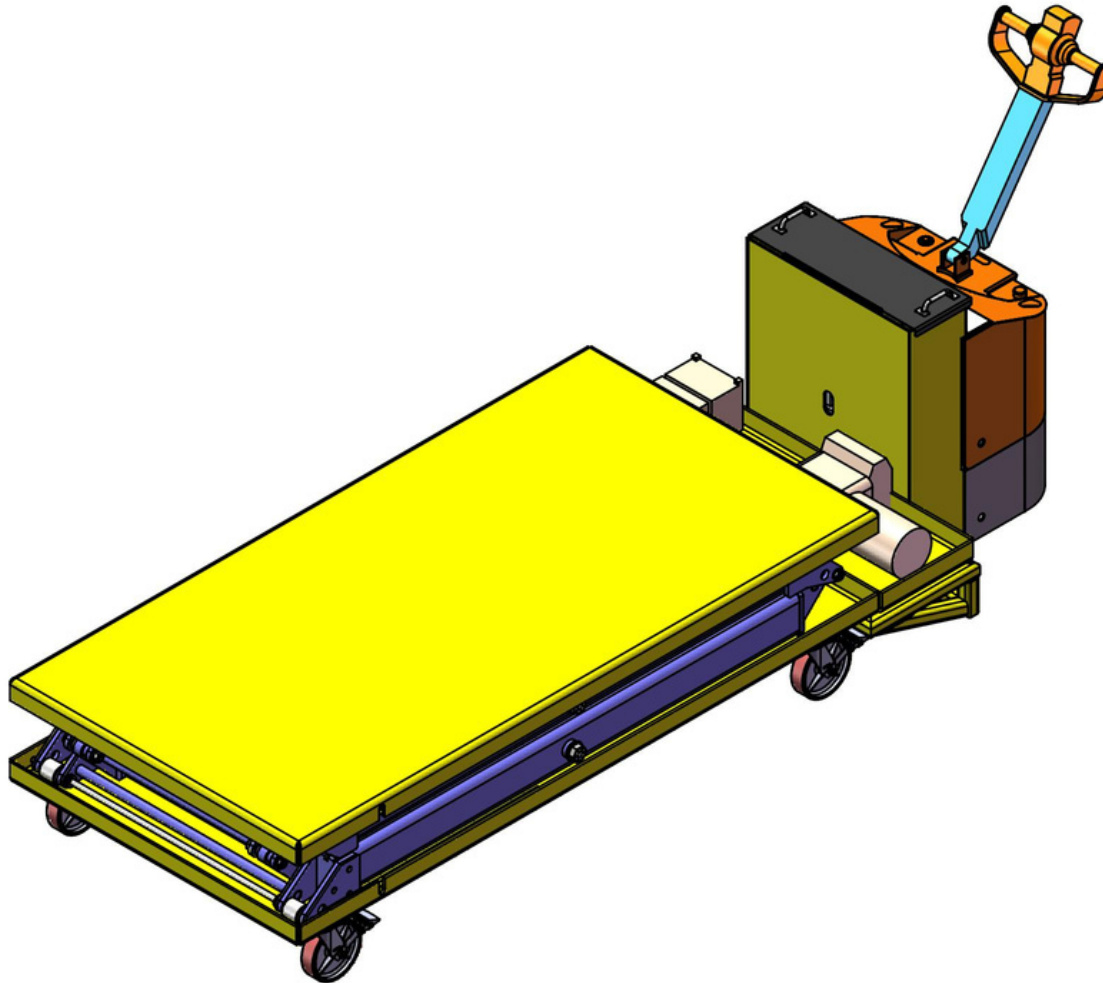

MATERIAL: STEEL

QUANTITY: 01
 WEIGHT: 4655.151 lbs
 HARDNESS: -

<p>CONFIDENTIAL</p> <p>The information illustrated and contained herein is not for publication and is issued in strict confidence on condition that it may not be used, copied, reprinted or disclosed to a third party either wholly or in part without prior Written Consent of:</p> <p>NITROLIFTS</p>		TOLERANCES UNLESS OTHERWISE SPECIFIED		TITLE:		
		2 Place Decimals	± 0.010	SCISSOR LIFT WITH ZOWELL TRUCK END		
		3 Place Decimals	± 0.005	DRAWN BY:	DATE:	DRAWING No.
		4 Place Decimals	± 0.0005	PT	09/29/2023	P23113-00A001
Angles		± 0°30'	3RD ANGLE PROJ.	SCALE:	SHEET:	
Fractional		± 1/16	☐ ©	1:25	1 of 2	
Break All Sharp Edges 1/64" x 45°					FINISH:	
					PAINTED	

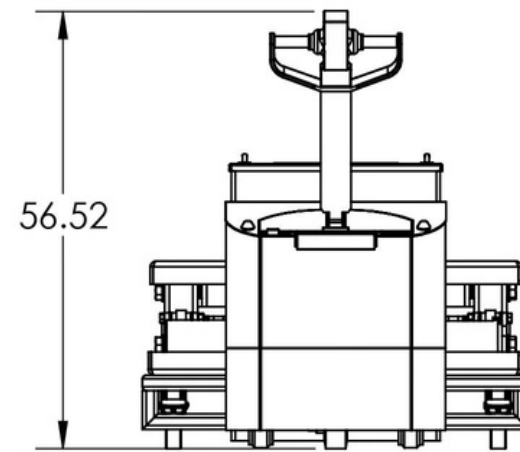
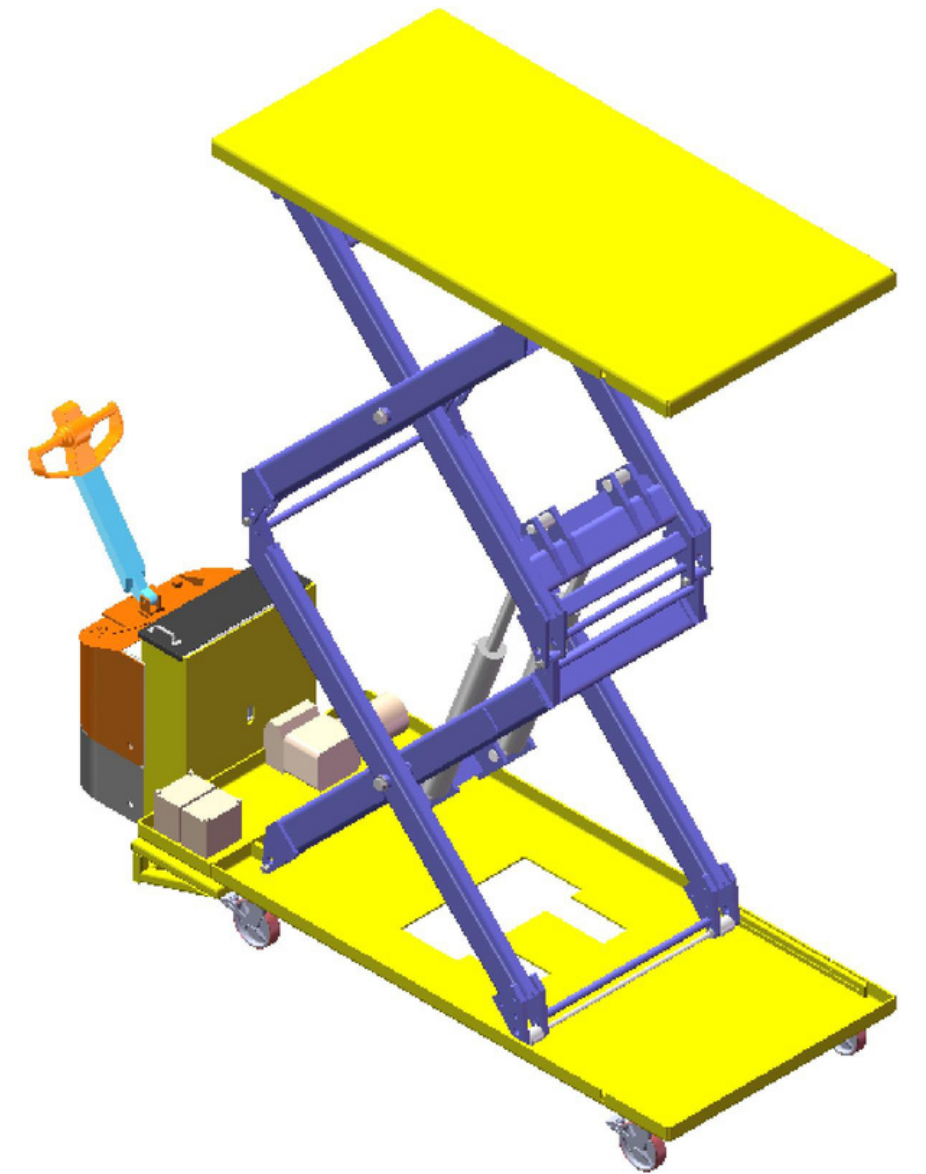
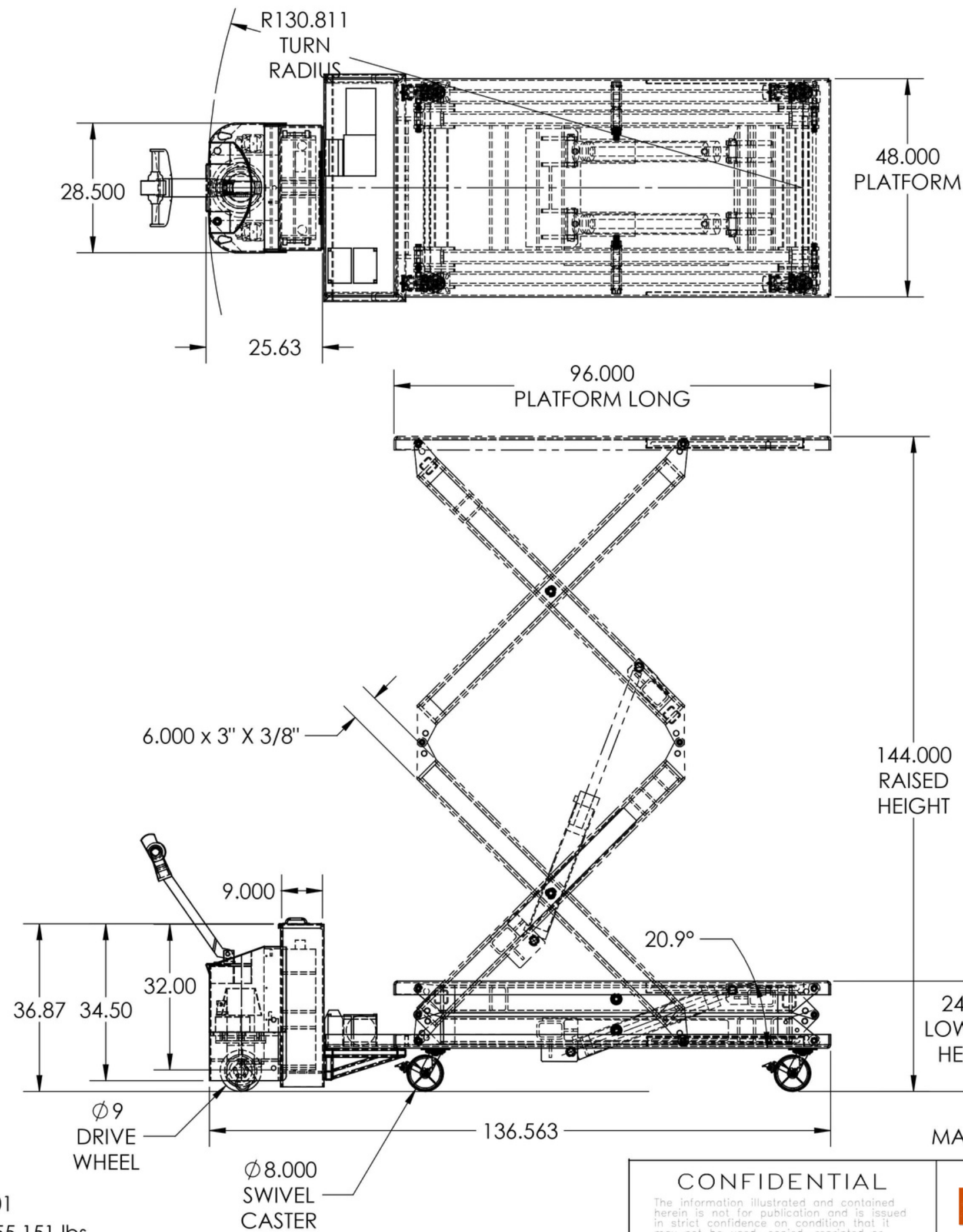

QUANTITY: 01
 WEIGHT: 4655.151 lbs
 HARDNESS: -

CONFIDENTIAL
 The information illustrated and contained herein is not for publication and is issued in strict confidence on condition that it may not be used, copied, reprinted or disclosed to a third party either wholly or in part without prior Written Consent of:
NITROLIFTS



DO NOT SCALE DRAWING

TOLERANCES UNLESS OTHERWISE SPECIFIED	
2 Place Decimals	± 0.010
3 Place Decimals	± 0.005
4 Place Decimals	± 0.0005
Angles	± 0'30"
Fractional	± 1/16
Break All Sharp Edges 1/64" x 45°	

TITLE: SCISSOR LIFT WITH ZOWELL TRUCK END			
DRAWN BY: PT	DATE: 09/29/2023	DRAWING No. P23113-00A001	
3RD ANGLE PROJ.	SCALE: 1:28	SHEET: 2 of 2	FINISH: PAINTED